

Physical site requirements : model HLF 5700

HEIGHT 1084 mm INCLUDES 110 mm LEGS: IT'S POSSIBLE TO HAVE DIFFERENT LEGS HEIGHT.

Countertop space : 27 inches (Width), 28 inches (Depth), 44 inches (Height) (Machine Only);

additional 10,3 inches (Width) with Milk fridge on the left / right side;
 additional 10,3 inches (Width) with Cup warmer on the left / right side;
 additional 18,1 inches (Width) with Cash box on the left side;

A DRAIN HOSE ACCESS HOLE IN THE COUNTER TOP MAY BE REQUIRED;

Countertop must be able to support : 154 lb (Machine Only);
 additional 60 lb with Milk fridge on the right side;
 additional 44 lb with Cup warmer on the left side;
 additional 33lb with Cash box on the left side;

Power requirements : (FOR EU)
 250 V AC, 10 AMP dedicated circuit using a SHUKO receptacle.

(FOR AU)
 230 V AC, 10 AMP dedicated circuit using an AS 3112 receptacle.

(FOR US)
 125 V AC, 15 AMP dedicated circuit using a NEMA 5-15 receptacle;

(FOR UK)
 250 V AC, 13 AMP dedicated circuit using a BS 1363 receptacle.

ELECTRICAL RECEPTACLE MUST BE LOCATED WITHIN 1,5 m OF THE MACHINE.

Plumbing requirements : Cold water source with a dedicated female 3/4" fitting and an in-line shut-off valve.

Water supply pressure must be MIN 1 bar (14,5 PSI) and MAX 6 bar (87 PSI).

WATER LINE MUST BE LOCATED WITHIN 1,5 m OF THE MACHINE.
 If your location has a reverse osmosis system, a fresh water bypass is required.

Room temperature : cannot exceed 32 °C (90 °F).

Piegatura	———
Piegatura contraria	- - - - -
Senso di Saturatura	←————→
Saturatura opposta	←-----→
Punto attacco laser	*
Superficie in vista	—————
Quota sotto controllo	xx

LEGENDA

Drain system requirements:

- It's important that the drain hose has a continuous rate of fall.
- Minimum rate of fall required is one inch for foot (85mm per meter)
- Internal diameter of the tube junction on the machine 0,76 inches.
- Internal diameter of the tube junction on the drain 0,82 inches.

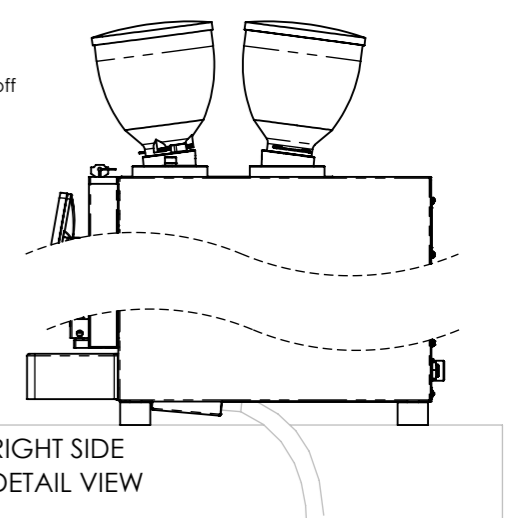

00	--	Prima edizione	-	-	-
N°	Pos.	Descrizione Modifica	Disegnato	Approvato	Data
IL PARTICOLARE DEVE ESSERE CONFORME ALLA DIRETTIVA 2002/95/CE (RoHS) E ALLE DIRETTIVE EN 60335-1 E 60335-2-75, AD ECCEZIONE DEI COMPONENTI 120 VAC (UL)			Specifiche di Fornitura HLF : --		
Tolleranze generali per grandezze lineari ed angolari prive di indicazioni di tolleranze specifiche : UNI EN 22768/1 - m Tolleranze geometriche per elementi privi di indicazione di tolleranze specifiche : UNI EN22768/2 - k					
Stato : DEFINITIVO VALIDO PER PRODUZIONE E/O ACQUISTO	Mod. Rif : 5700	Note : --	Peso (Kg) : 70	Disegnato : Bernardel L.	Controllato : --
	Finitura : --		Data : 12/05/2020	Data : --	Approvato : --
HLF ITALIAN DESIGN	Materiale : --	Ricavato da : --		Sostituisce il : --	
	Denominazione : PLANNING DIAGRAM 5700 (INCH)	COD. Articolo : --		Rev. 00	